

ADDENDUM CC-3

TO THE

PROJECT MANUAL AND DRAWINGS

FOR

DLR Group  
6225 North 24th Street, Suite 250  
Phoenix, AZ 85016  
(602) 381-8580

March 19, 2010

GILA COUNTY PUBLIC WORKS PROJECTS  
GLOBE, ARIZONA

DLR GROUP PROJECT NOS. 30-09115-00 AND 30-09118-00  
BID DOCUMENTS NO. 110109-1

FOR

COMBINED CONTRACT

APPF  
GILA CO  
PERMIT  
DATE:..

POSTED 7-8-10



NOTICE TO BIDDERS: The Project Manual and Drawings to the above referenced project are hereby amended as follows:

## PROJECT MANUAL

### ITEM NO. 1 - VOLUME 1 - SECTION 00 0110 - TABLE OF CONTENTS

- a. At Table of Contents, Volume 3, Division 26, add the following after "Section 26 2200 Low-Voltage Transformers" and before "Section 26 2416 Panelboards".  
"Section 26 2413 Switchboards"

### ITEM NO. 2 - VOLUME 1 - SECTION 00 2113 - INSTRUCTIONS TO BIDDERS

- a. At clause IB 4.4.2.a, add the following:  
"including Offer Page."
- b. At subparagraph IB 4.1.6, delete the words "Waiver of Liability and Release Form" and substitute the words "Bid Security and Photocopy of Contractor's License as required by paragraph IB 4.4 below."

### ITEM NO. 3 - VOLUME 1 - SECTION 08 3323 - OVERHEAD COILING DOORS

- a. At subparagraph 2.1.A, add the following:  
"7. Janus International."

### ITEM NO. 4 - VOLUME 2 - SECTION 26 2413 - SWITCHBOARDS

- a. At paragraph 2.1 Manufacturers: Delete 'EATON' and 'SIEMENS'.

### ITEM NO. 5 - VOLUME 2 - SECTION 26 2416 - PANELBOARDS

- a. At paragraph 2.1 Manufacturers: Delete 'EATON' and 'SIEMENS'.

### ITEM NO. 6 - VOLUME 3 - SECTION 22 1319 - SANITARY WASTE PIPING SPECIALTIES

- a. Paragraph 2.2, add the following:
  - "B. Floor Sinks Type FS: Comply with ASME A1112.21.1M.
    1. Jay R. Smith: Figure 3100.
    2. Body Material: Gray iron.
    3. Seepage Flange: Not required.
    4. Clamping Device: Not required.
    5. Outlet: Bottom.
    6. Exposed Surfaces and Interior Lining: Acid-resistant enamel.
    7. Sediment Bucket: Not required.
    8. Top or Strainer Material: Nickel bronze.
    9. Top Shape: Square,  $\frac{3}{4}$  grate.
    10. Dimensions of Top Strainer: 8-1/2 inches.
    11. Funnel: Not required.

I-C  
OVER  
JNTY COI  
#: 0  
7-7

ITEM NO. 7 - VOLUME 3 - SECTION 22 4000 - PLUMBING FIXTURES

- a. Subparagraph 3.8.A: Add the following Sink Data Sheet:

"SINK DATA SHEET

Sinks, Type S-2: Turbo Air (TSA-2-D1) – 72" two-compartment sink (Green World Series)

Material: Stainless steel

Gage: 18 (304)

Sink Type: Two compartment with drain boards on each side.

Sink Dimensions: 72x44-1/2x24 inches, 34 inches to rim.

Bowl Dimensions: 18x18x11 inches.

Mounting: Floor.

Fittings and Accessories: Provide the following compatible components:

Supplies: Sink Type 2

Faucet: Chicago Faucet 540-LDLESSSPTXKCP.

Handles: Chicago Faucet 317-PLJKVP, dual 4" wrist blades.

Spout: Chicago Faucet GN8BVBJKCP, rigid/swing spout w/atmospheric vacuum breaker, 9-1/2" height to top of spout, 8" inlet to outlet projection, 5-3/4" height to outlet, chrome finish. Provide 3/4" male threaded outlet.

Drain: (2) 304 stainless grid with polished finish, similar to Elkay LK18B.

Trap: Sink Type 2 with continuous waste Type 1."

ITEM NO. 8 - VOLUME 3 - INDEX - DIVISION 26 - ELECTRICAL

- a. At Division Index, add the following after Section 26 2200 Low-Voltage Transformers and before Section 26 2416 Panelboards:

"Section 26 2413 Switchboards.....26 2413-1; 6"

ITEM NO. 9 - VOLUME 3 - SECTION 26 2413 - SWITCHBOARDS

- a. Add new Section 26 2413 Switchboards per Attachment E7 to Addendum CC-3 dated March 19, 2010.

ITEM NO. 10 - VOLUME 3 - SECTION 26 2416 - PANELBOARDS

- a. At paragraph 2.1 Manufacturers: Delete 'EATON' and 'SIEMENS'.

**DRAWINGS**

Public Works Administration Building

ITEM NO. 11 - SHEET A1.1 – FLOOR PLAN

- a. At MDF 124, flip Door 124 to swing into room.  
b. At Lobby 100, delete window tag designation "B" and replace with window tag designation "A".

DE  
FIE  
MUNIT  
2911  
10

ITEM NO. 12 - SHEET A10.1 – GENERAL BUILDING DETAILS

- a. At Detail 15/A10.1, delete note "GYPSUM BOARD OVER METAL STUDS – SEE FLOOR PLAN FOR WALL TYPES" and substitute note "5/8" GYPSUM BOARD OVER 3/8" METAL STUDS WHERE OCCURS – SEE FLOOR PLAN FOR LOCATIONS".

ITEM NO. 13 - SHEET M1.1 - HVAC FLOOR PLAN

- a. Relocate IU-3 per Attachment M-1 to Addendum CC-3 dated March 19, 2010.

ITEM NO. 14 - SHEET M1.2 - HVAC PIPING FLOOR PLAN

- a. Modify refrigerant and condensate piping per Attachment M-2 to Addendum CC-3 dated March 19, 2010.

ITEM NO. 15 - SHEET EC.2 - LIGHTING FIXTURE SCHEDULE

- a. Add the acceptable lighting fixture manufacturers for each fixture types as follows:
  - 1. SF1, SF1N, XW, EM, EBW1, EBW2, EBW3: Cooper Lighting

ITEM NO. 16 - SHEET ES.1 - LIGHTING FIXTURE SCHEDULE

- a. Delete this sheet entirely. Add new sheet ES.1 per Attachment E1 to Addendum CC-3 dated March 19, 2010.

ITEM NO. 17 - SHEET E5.2 - ELECTRICAL DETAILS

- a. Delete this sheet entirely. Add new sheet E5.2 per Attachment E2 to Addendum CC-3 dated March 19, 2010.

ITEM NO. 18 - SHEET E6.1 - ELECTRICAL ONE-LINE DIAGRAM

- a. From panel 'HAB' via transformers, delete the panel designations 'CF, LFA, LFB'. Add new designations 'CB, LAC, LAD' per Attachment E3 to Addendum CC-3 dated March 19, 2010.

Facilities and Sign Shop

ITEM NO. 19 - SHEET 0.0 - INDEX OF DRAWINGS

- a. At Index of Drawings, Electrical Sheets, add the following before Sheet E1.2:  
"E1.1 NOT USED"
- b. At Index of Drawings, Electrical Sheets, add the following before Sheet E2.2:  
"E2.1 NOT USED"
- c. At Index of Drawings, Electrical Sheets, add the following before Sheet E4.2:  
"E4.1 NOT USED"

ITEM NO. 20 - SHEET A9.1 – DOOR AND FRAME SCHEDULE AND DETAILS

- a. Delete Window Schedule entirely.
- b. Delete Details 22/A9.1, 32/A9.1, and 42/A9.1 entirely.

ITEM NO. 21 - SHEET P1.1 - PLUMBING FLOOR PLANS

- a. Add S-2, SS-1, FS-1 and modify plumbing per Attachment M-3 to Addendum CC-3 dated March 19, 2010.

3  
LD  
DEV  
01  
BY: S

ITEM NO. 22 - SHEET P4.1 - PLUMBING DETAILS, SCHEDULES, AND RISERS

- a. Modify WASTE AND VENT RISER per Attachment M-4 to Addendum CC-3 dated March 19, 2010.
- b. Modify DOMESTIC WATER RISER per Attachment M-5 to Addendum CC-3 dated March 19, 2010.
- c. Modify PLUMBING FIXTURE SCHEDULE per Attachment M-6 to Addendum CC-3 dated March 19, 2010.
- d. Add SEPARATOR – SOLIDS SCHEDULE per Attachment M-6 to Addendum CC-3 dated March 19, 2010.

ITEM NO. 23 - SHEET EC.2 - LIGHTING FIXTURE SCHEDULE

- a. Add the acceptable lighting fixture manufacturers for each fixture types as follows:
  1. SF1, SF1N, XW, EM, EBW1, EBW2, EBW3: Cooper Lighting

ITEM NO. 24 - SHEET ES.1 - PARTIAL ELECTRICAL SITE PLAN

- a. Delete this sheet entirely. Add new sheet ES.1 per Attachment E4 to Addendum CC-3 dated March 19, 2010.

ITEM NO. 25 - SHEET E4.2 - SPECIAL SYSTEMS MAIN PLAN

- a. Delete this sheet entirely. Add new sheet E4.2 per Attachment E5 to Addendum CC-3 dated March 19, 2010.

ITEM NO. 26 - SHEET E4.3 - SPECIAL SYSTEMS MEZZANINE PLAN

- a. Delete General Notes D through L.

ITEM NO. 27 - SHEET E5.2 - ELECTRICAL DETAILS

- a. Delete this sheet entirely. Add new sheet E5.2 per Attachment E6 to Addendum CC-3 dated March 19, 2010.

END of ADDENDUM CC-3

COP  
LOPMEI

lop

\\pnc201\Projects\30-09115-00\dwg\Mezz-hv\adwg - Mar 12, 2010 1:53pm - bberggren

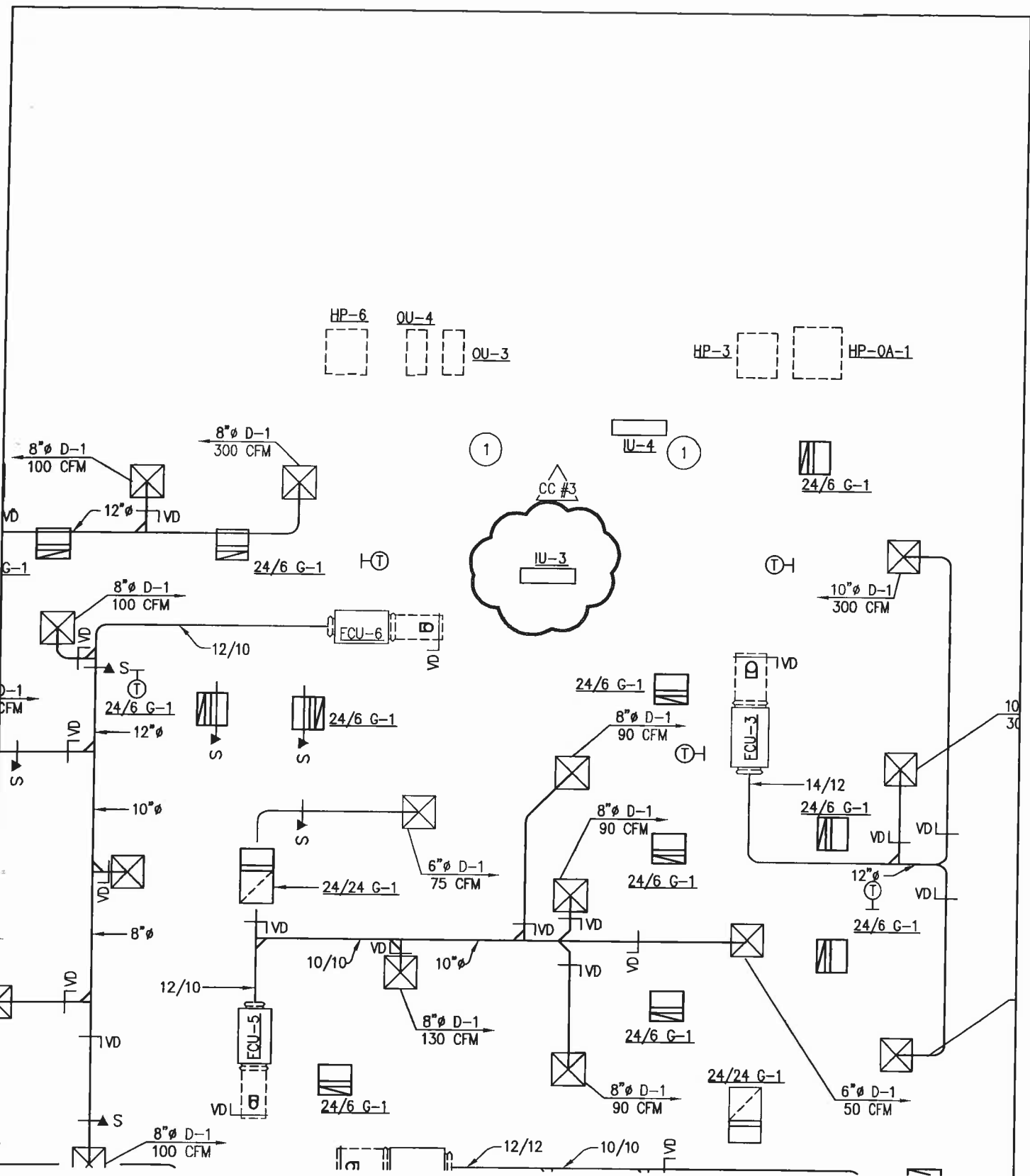

**HVAC FLOOR PLAN**  
 NORTH SCALE: 1/8" = 1'-0"

Attachment No. M1  
 to Addendum No. CC-3  
 Dated: March 19, 2010

**DLR Group**  
 Architecture Engineering Planning Interiors  
© 2008, DLR Group Inc., an Arizona corporation. ALL RIGHTS RESERVED.

**M1.1**  
 30-09115-00  
 AUGUST 11, 2009

**HVAC FLOOR PLAN**  
**GILA COUNTY**  
**PUBLIC WORKS PROJECTS**

\\phx201\projects\30-08115-00\dwg\me\zz-plla.dwg - Mar 12, 2010 1:57pm - bbergrren

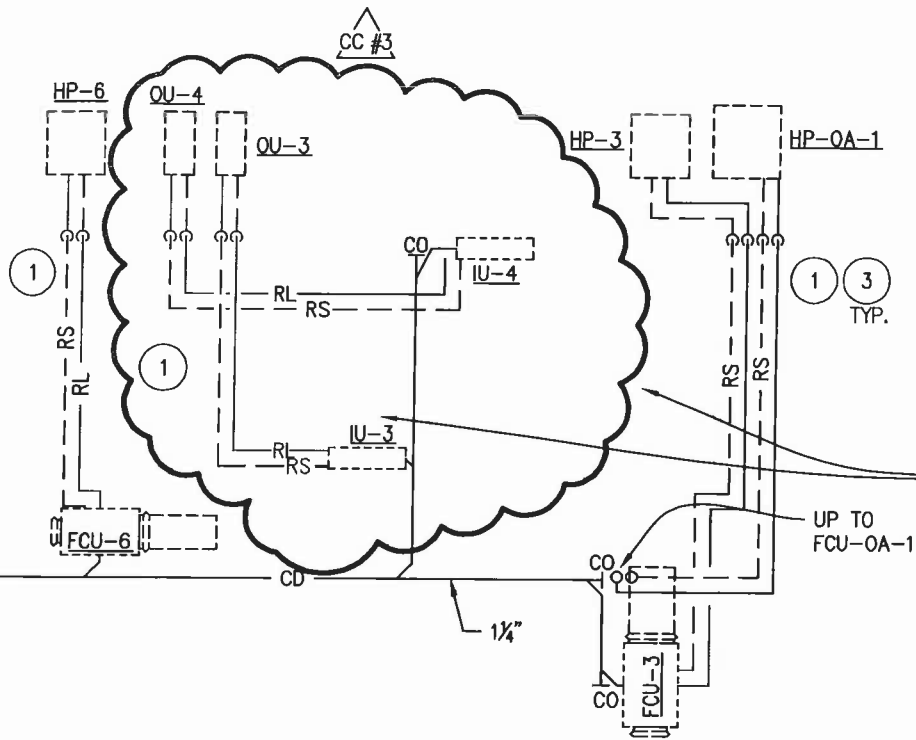

COORDINATE ROUTING OF PIPING IN THIS ROOM WITH EQUIPMENT AND OTHER CONTRACTORS

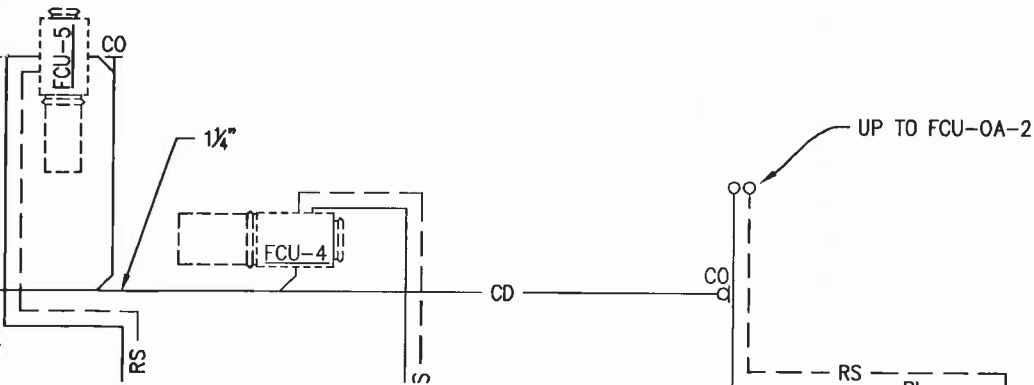

# HVAC PIPING FLOOR PLAN

NORTH SCALE: 1/8" = 1'-0"

Attachment No. M2  
to Addendum No. CC-3  
Dated: March 19, 2010

APP  
GILA C  
PERM  
DATE

\\phx201\proj\proj\30-09118-00\dwg\pl\zz-pfa.dwg - Mar 12, 2010 2:05pm - bberggren

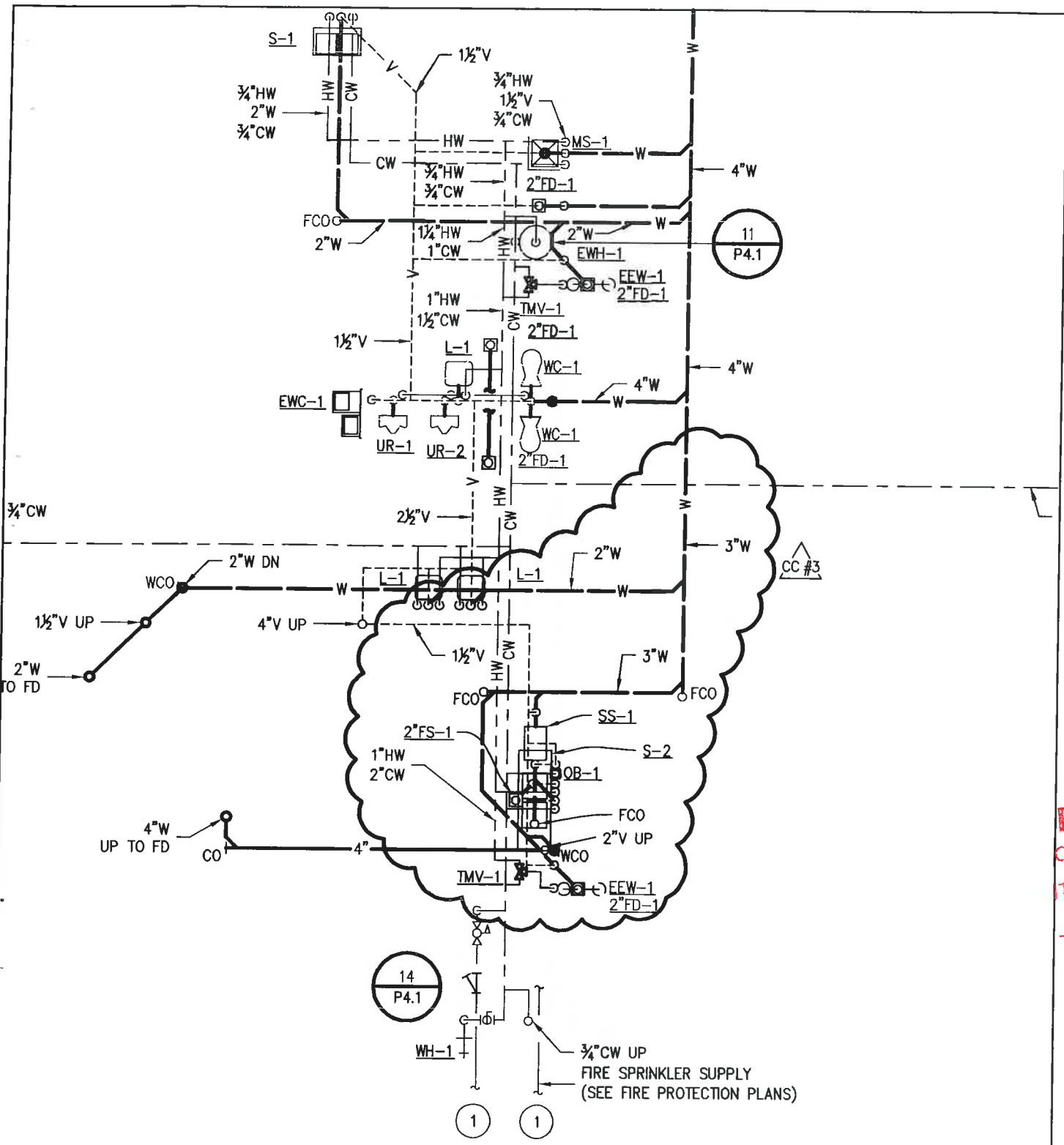

1-  
ROVI  
COUNTY C  
IT #:  
7-

# PLUMBING FLOOR PLAN - FIRST LEVEL

NORTH SCALE: 1/8" = 1'-0"

Attachment No. M3  
to Addendum No. CC-3  
Dated: March 19, 2010

**DLR Group**  
Architecture Engineering Planning Interiors  
© 2009, DLR Group Inc., an Arizona corporation. ALL RIGHTS RESERVED.

**P1.1**  
30-09118-00  
11/02/2009

PLUMBING FLOOR PLANS  
GILA COUNTY  
FACILITIES AND SIGN SHOP BUILDING



\\phx201\A\Projects\30-0911B-00\dwg\Pl\zz-p401.dwg - Mar 16, 2010 11:34am - bberggren

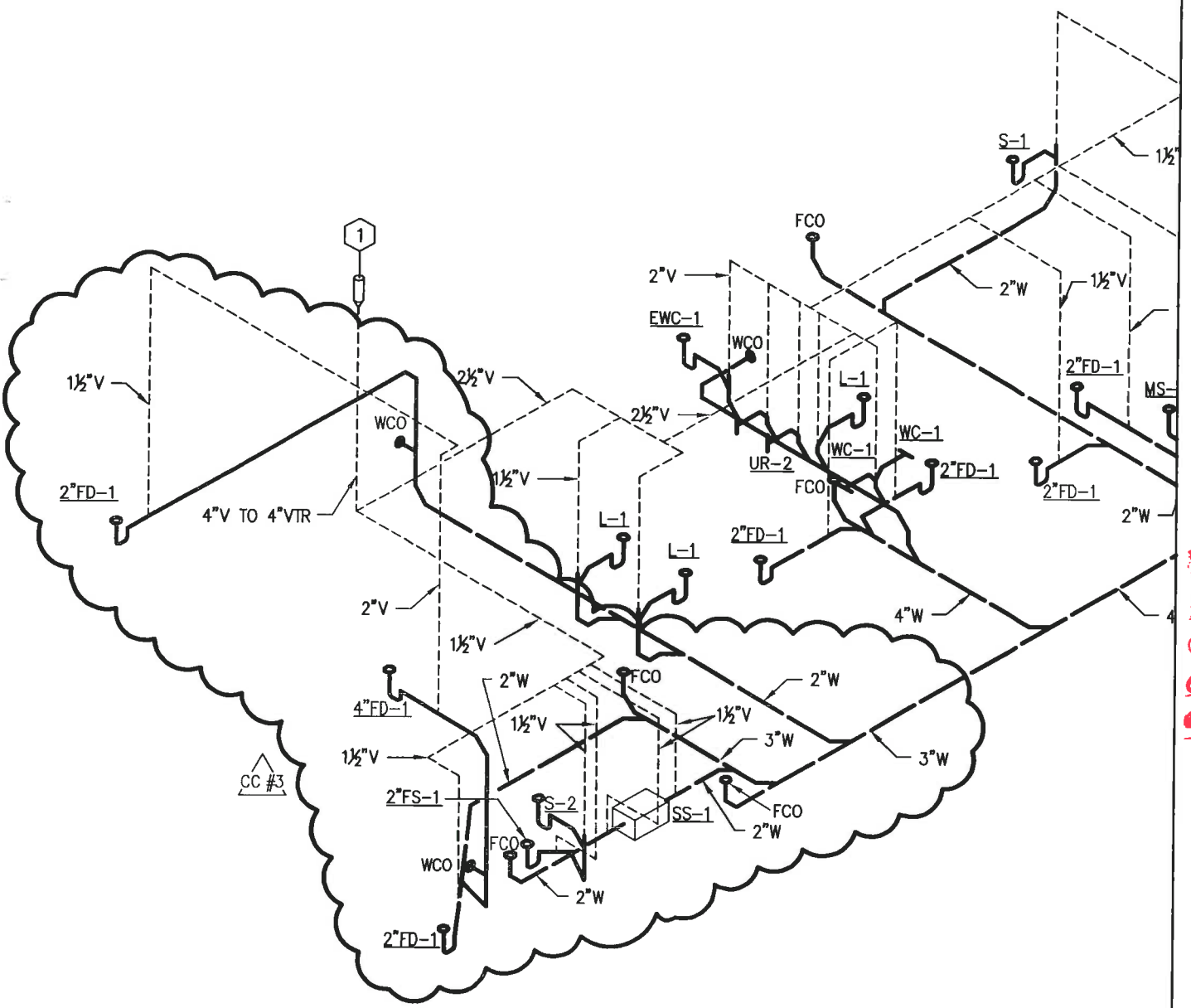

COD  
ED FI  
COMMUN  
609  
9.10

# WASTE AND VENT RISER

NOT TO SCALE

Attachment No. M4  
to Addendum No. CC-3  
Dated: March 19, 2010

**DLR Group**  
Architecture Engineering Planning Interiors  
© 2009, DLR Group Inc., an Arkansas corporation. ALL RIGHTS RESERVED.

**P4.1**  
30-0911B-00  
11/02/2009

PLUMBING DETAILS, SCHEDULES, AND RISERS  
GILA COUNTY  
FACILITIES AND SIGN SHOP BUILDING

\\phx201\Projects\30-0911B-00\dwg\PL\zz-p401.dwg - Mar 16, 2010 8:12am - bbergrren

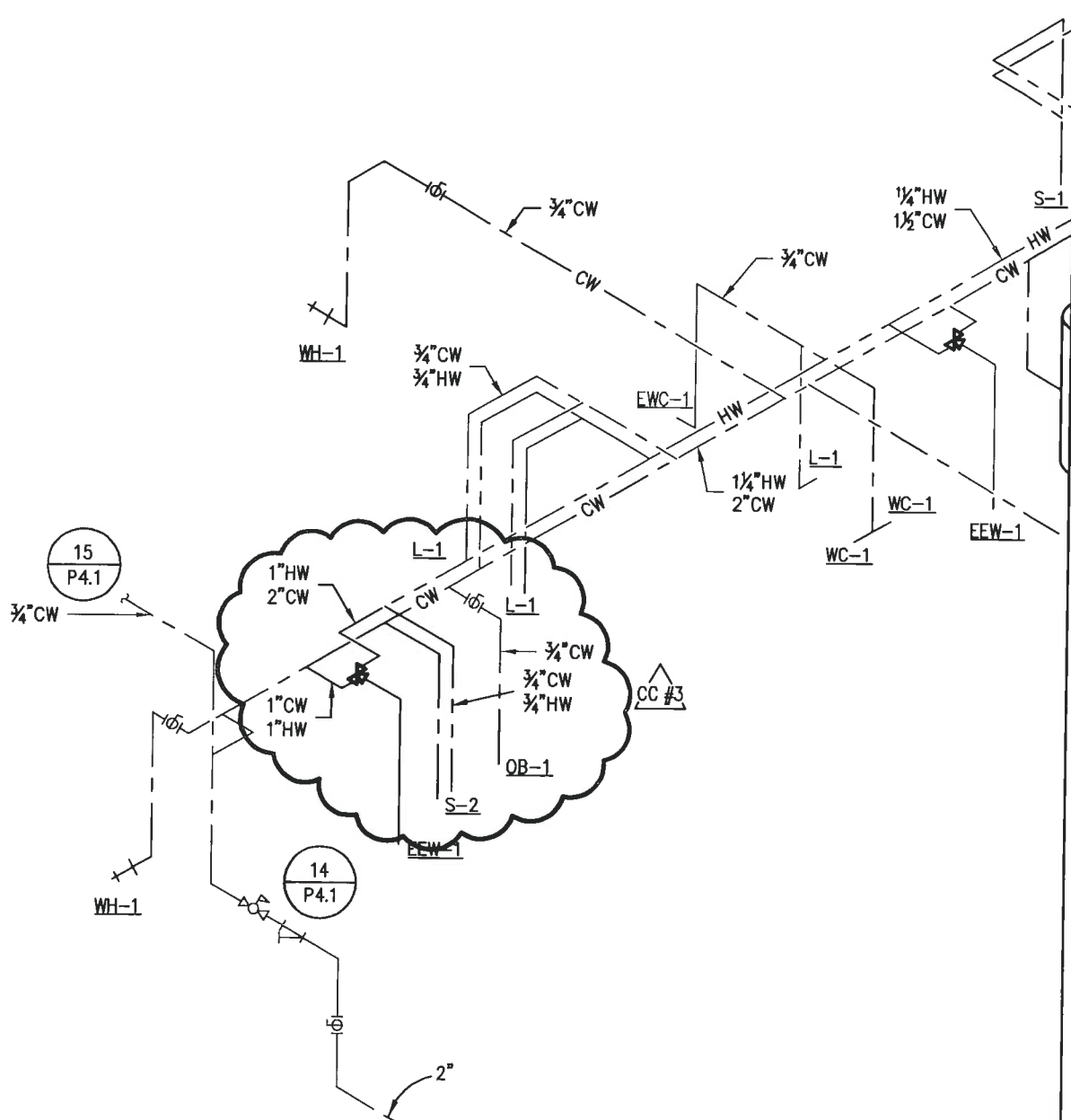

ES  
ELD  
TY DEVE  
11-01  
BY: C

# DOMESTIC WATER RISER

NOT TO SCALE

Attachment No. M5  
to Addendum No. CC-3  
Dated: March 19, 2010

**DLR Group**  
Architecture Engineering Planning Interiors  
© 2009, DLR Group Inc., an Arizona corporation. ALL RIGHTS RESERVED.

**P4.1**  
30-0911B-00  
11/02/2009

PLUMBING DETAILS, SCHEDULES, AND RISERS  
GILA COUNTY  
FACILITIES AND SIGN SHOP BUILDING

**PLUMBING FIXTURE SCHEDULE**

MARK	FIXTURE	LOCAL CONNECTIONS				MOUNTING HEIGHT
		CW (IN)	HW (IN)	WASTE (IN)	VENT (IN)	
WC-1	WATER CLOSET (HANDICAP)	1"	-	4"	2"	14"
UR-1	URINAL	-	-	2"	1-1/2"	24"
UR-2	URINAL	-	-	2"	1-1/2"	17"
L-1	LAVATORY	1/2"	1/2"	2"	1-1/2"	34" TO RIM
S-1	SINK (GENERAL)	1/2"	1/2"	2"	1-1/2"	COUNTER
S-2	SINK (WORK ROOM)	3/4"	3/4"	2"	1-1/2"	36" TO RIM
MS-1	UTILITY SINK	1/2"	1/2"	3"	1-1/2"	FLOOR
EWC-1	ELEC. WATER COOLER	1/2"	-	2"	1-1/2"	34"
WH-1	WALL HYDRANT	3/4"	-	-	-	18" AFG
EEW-1	EMERGENCY EYEWASH	1"	1"	-	-	PEDESTAL
OB-1	ICE MACHINE WATER OUTLET	1/2"	-	-	-	3'-0" AFF
FCO	FLOOR CLEANOUT	-	-	-	-	FLOOR
WCO	WALL CLEANOUT	-	-	-	-	WALL
2WCCO	2 WAY GRADE CLEANOUT	-	-	-	-	FLOOR
FD	FLOOR DRAIN	-	-	-	-	FLOOR

CC #3

CC #3

**SEPARATOR - SOLIDS SCHEDULE**

MARK	LOCATION	TYPE	GPM	INLET/OUTLET (IN)	PRIMARY FILTER CAPACITY (GAL)	COLLECTION CHAMBER CAPACITY (GAL)	COVER DIMENSIONS (IN)	BASIS OF DESIGN	MECH NOTES
SS-1	WORK ROOM 103	BELOW FLOOR	10	2	1.4	10	16x24	SCHIER PS-10-F	1,2

**MECHANICAL NOTES:**

1. 3/8" HDPE WALLS, POLYETHYLENE GASKETED COVER W/SS BOLTS, INTEGRAL AIR RELIEF / ANTI-SIPHON.
2. PROVIDE CUSTOM EXTENSION IF REQUIRED (EXT).

Attachment No. M6  
to Addendum No. CC-3  
Dated: March 19, 2010

COPY  
LOPME  
1  
SP

\\phx201\Projects\30-0911B-00\dwg\PI\z-p401.dwg - Mar 12, 2010 2:24pm - bberengren



GILA CO. PUBLIC WORKS ADMINISTRATION  
 ELECTRICAL SITE PLAN  
 CONSTRUCTION DOCUMENT SUBMITTAL

ES.1  
 2018.02  
 1:00000  
 1:00000  
 1:00000  
 1:00000

DLR Group  
 Architecture Engineering Planning Interiors

Approved for E.P.  
 License No. 12345  
 Date: 12/31/2018

**LEGEND NOTES**

1. ALL ELECTRICAL SYMBOLS AND NOTATION SHALL BE IN ACCORDANCE WITH THE NATIONAL ELECTRICAL CODE (NEC) AND THE NATIONAL FIRE ALARM CODE (NFPA).
2. THE ELECTRICAL SYMBOLS AND NOTATION SHALL BE IN ACCORDANCE WITH THE NATIONAL ELECTRICAL CODE (NEC) AND THE NATIONAL FIRE ALARM CODE (NFPA).
3. THE ELECTRICAL SYMBOLS AND NOTATION SHALL BE IN ACCORDANCE WITH THE NATIONAL ELECTRICAL CODE (NEC) AND THE NATIONAL FIRE ALARM CODE (NFPA).
4. THE ELECTRICAL SYMBOLS AND NOTATION SHALL BE IN ACCORDANCE WITH THE NATIONAL ELECTRICAL CODE (NEC) AND THE NATIONAL FIRE ALARM CODE (NFPA).

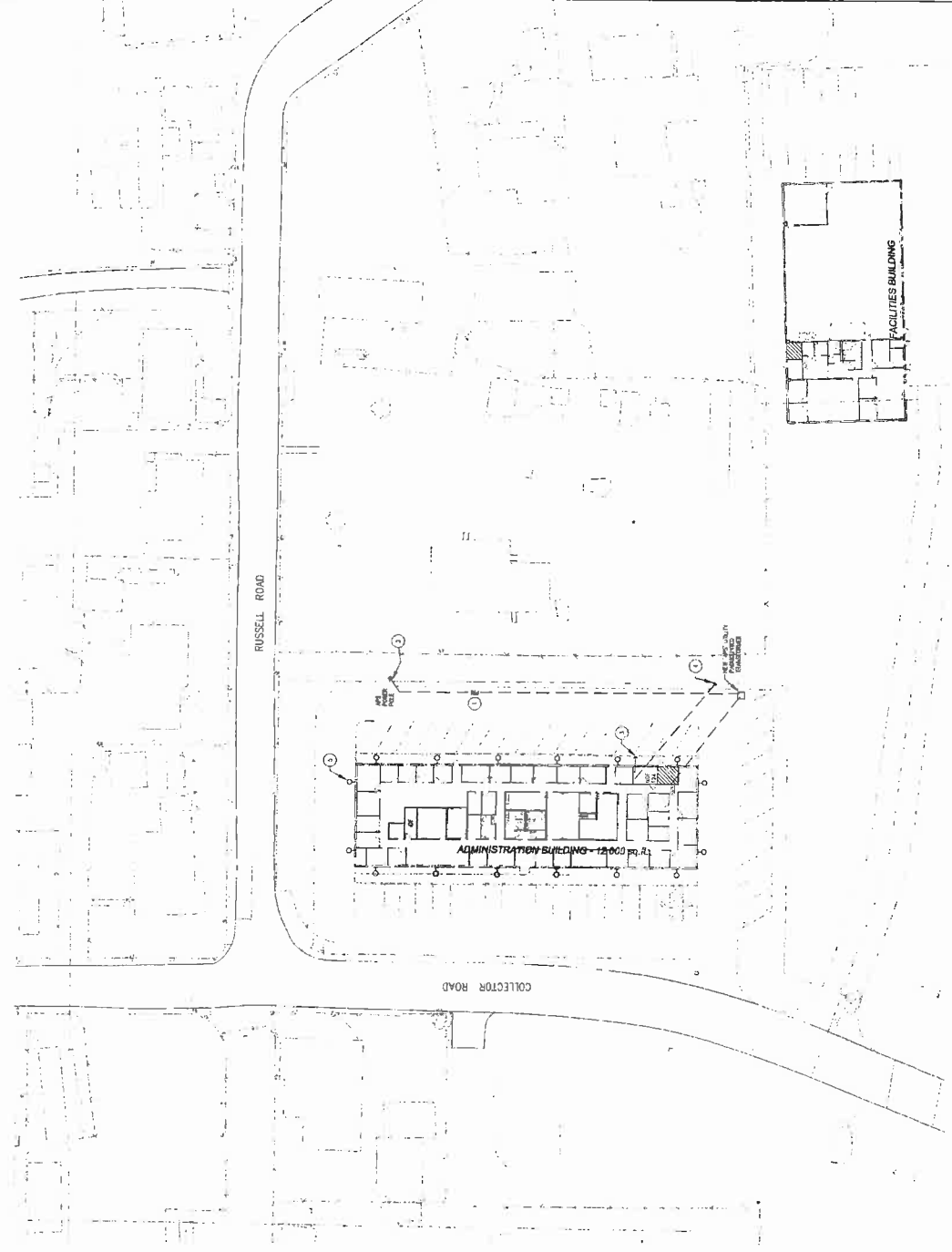

**ELECTRICAL SITE PLAN**  
 SCALE: 1" = 30'-0"  
 NORTH



(10) TYPICAL BROADBAND WALL FIELD AT MDF AND IDF

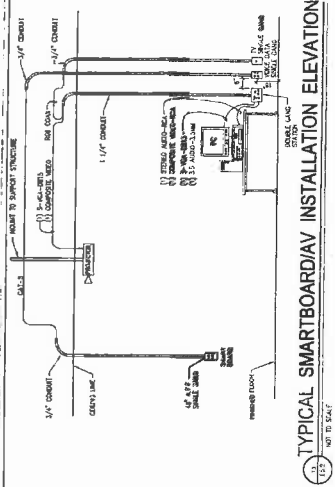

TYPICAL SMARTBOARD/AV INSTALLATION ELEVATION  
 NOT TO SCALE

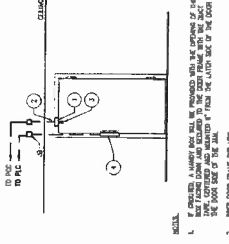

CONTROLLED DOORS  
 NOT TO SCALE

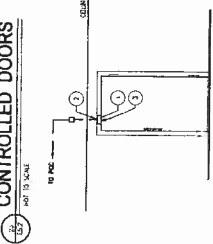

TYPICAL BROADBAND WALL FIELD AT MDF AND IDF  
 NOT TO SCALE



CONTROLLED DOORS  
 NOT TO SCALE

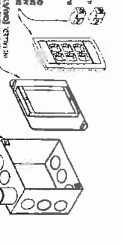

TYPICAL BROADBAND WALL FIELD AT MDF AND IDF  
 NOT TO SCALE

(11) TYPICAL VOICE AND DATA

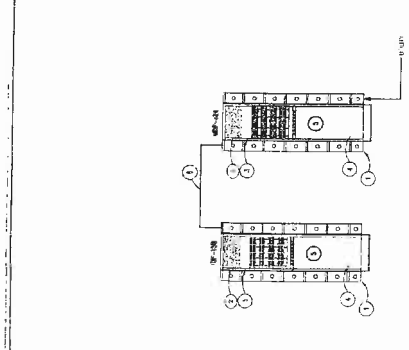

MDF / IDF SS RISER DIAGRAM  
 NOT TO SCALE

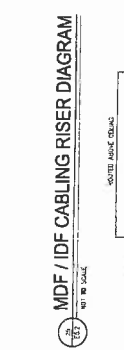

MDF / IDF CABLING RISER DIAGRAM  
 NOT TO SCALE

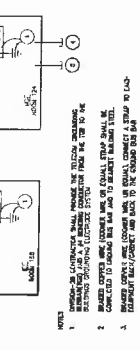

MDF / IDF SS RISER DIAGRAM  
 NOT TO SCALE



TYPICAL BROADBAND WALL FIELD AT MDF AND IDF  
 NOT TO SCALE



TYPICAL BROADBAND WALL FIELD AT MDF AND IDF  
 NOT TO SCALE

(12) FIRE ALARM SYSTEM RISER DIAGRAM

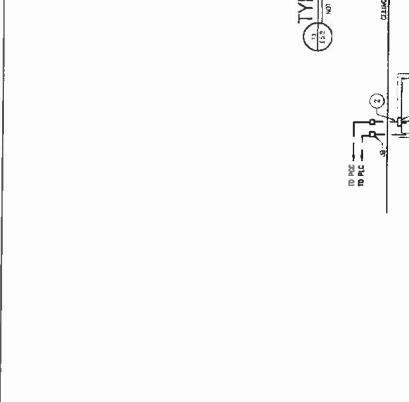

FIRE ALARM SYSTEM RISER DIAGRAM  
 NOT TO SCALE

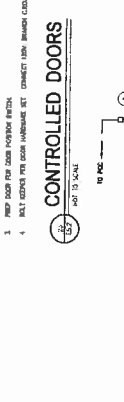

FIRE ALARM SYSTEM RISER DIAGRAM  
 NOT TO SCALE

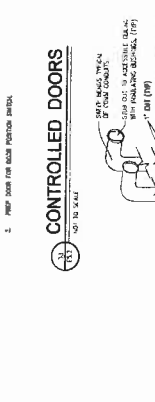

FIRE ALARM SYSTEM RISER DIAGRAM  
 NOT TO SCALE

L:\Projects\30-09115-00\dwg\E1\zz-E6-1.dwg - Mar 18, 2010 2:48pm - rtwoitase

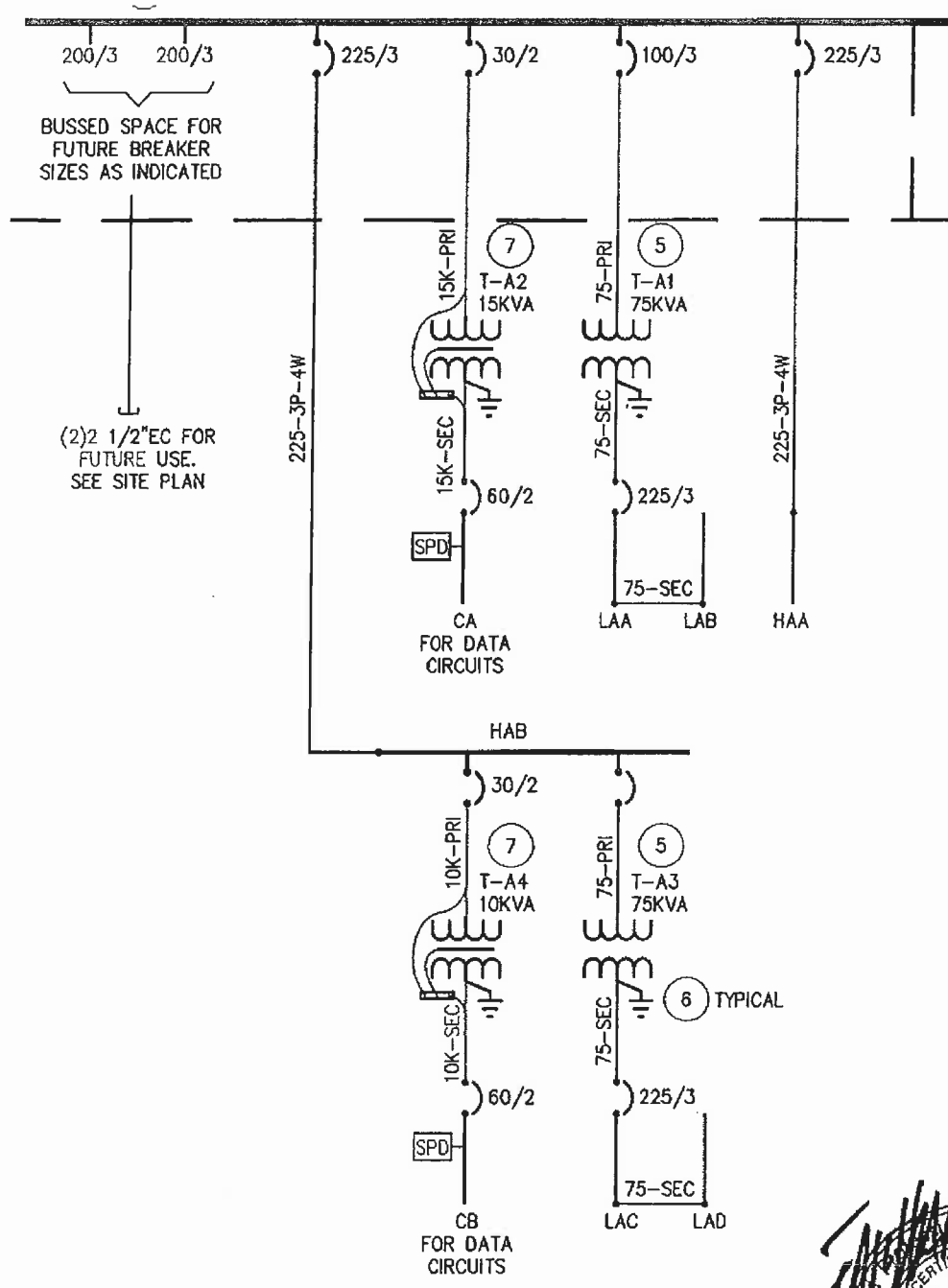

PROV  
COUNTY  
IT #:  
7-

# PARTIAL ONE - LINE DIAGRAM

NOT TO SCALE



Attachment No. E3  
to ADDENDUM CC-3  
Dated: 19 March 2010

**DLR Group**  
Architecture Engineering Planning Interiors  
© 2009. DLR Group Inc. All Rights Reserved.

**E6.1**  
30-09115-00  
AUGUST 11, 2009

**ELECTRICAL ONE - LINE DIAGRAM**  
**GILA COUNTY**  
**PUBLIC WORKS PROJECTS**



**PARTIAL ELECTRICAL SITE PLAN**  
**GILA COUNTY FACILITIES & SIGN SHOP**  
**CONSTRUCTION DOCUMENT SUBMITTAL**

**ES.1**  
 1/20/2008  
 1/20/2008  
 1/20/2008

**DLR Group**  
 Architecture Engineering Planning Interiors

**LEGEND NOTES**

1. ALL ELECTRICAL SYMBOLS AND NOTATION SHALL BE IN ACCORDANCE WITH THE NATIONAL ELECTRICAL CODE (NEC) AND THE NATIONAL FIRE ALARM AND SIGNAL CODE (NFPA 72).
2. THE ELECTRICAL SYSTEM SHALL BE DESIGNED TO SERVE ALL LOADS SHOWN ON THIS PLAN AND TO BE CAPABLE OF BEING EXPANDED TO ACCOMMODATE FUTURE DEVELOPMENT.
3. THE ELECTRICAL SYSTEM SHALL BE DESIGNED TO BE CAPABLE OF BEING EXPANDED TO ACCOMMODATE FUTURE DEVELOPMENT.
4. THE ELECTRICAL SYSTEM SHALL BE DESIGNED TO BE CAPABLE OF BEING EXPANDED TO ACCOMMODATE FUTURE DEVELOPMENT.
5. THE ELECTRICAL SYSTEM SHALL BE DESIGNED TO BE CAPABLE OF BEING EXPANDED TO ACCOMMODATE FUTURE DEVELOPMENT.

**KEY PLAN**

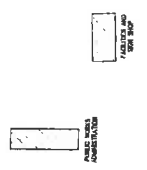

**PARTIAL ELECTRICAL SITE PLAN**  
 SCALE: 1" = 300'

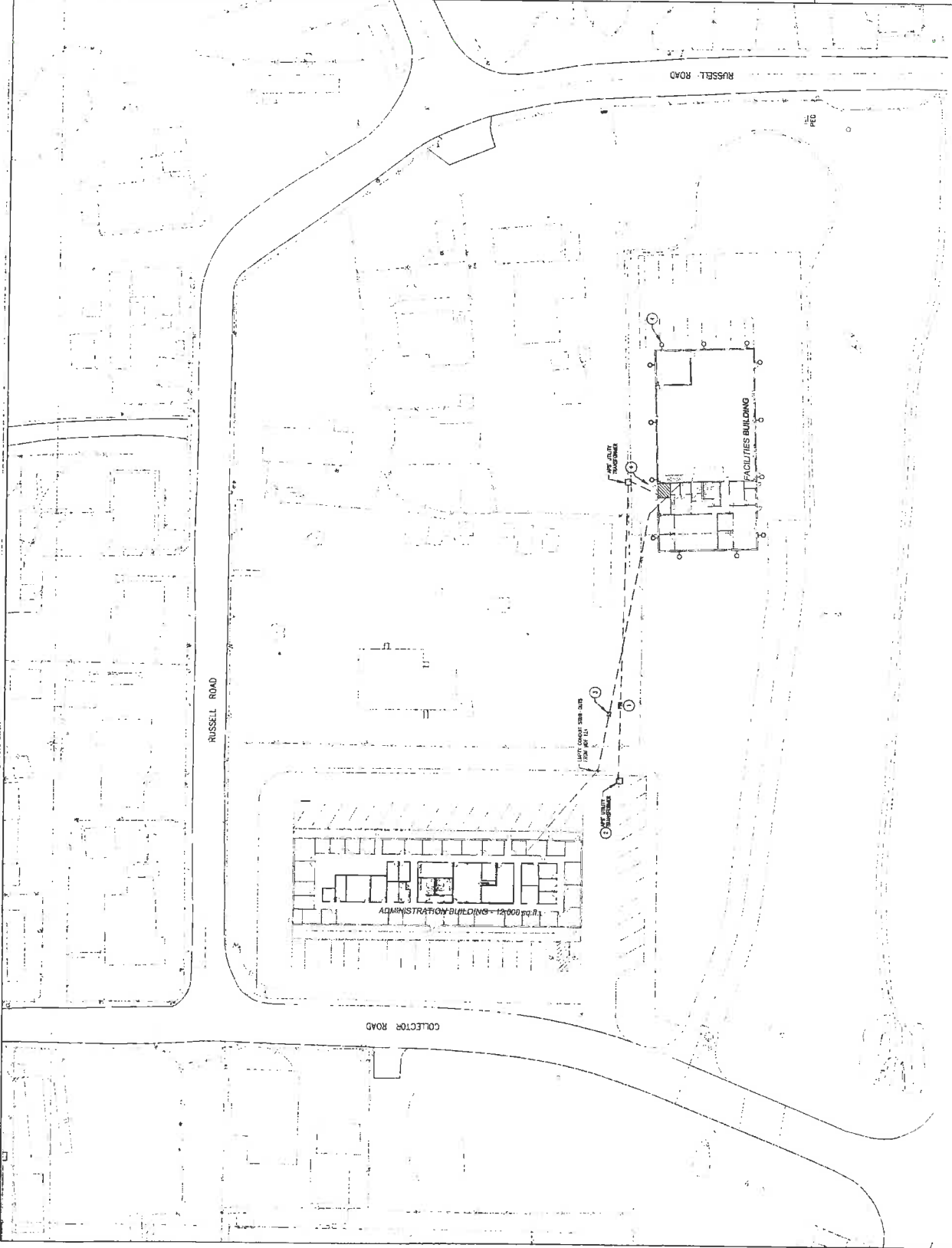

**-COL**  
**ED F**  
**COMMUI**  
**609**  
**1-10**







SECTION 26 2413 - SWITCHBOARDS

PART 1 - GENERAL

1.1 RELATED DOCUMENTS

- A. Drawings and general provisions of the Contract, including General Conditions and Division 01 Specification Sections, apply to this Section.
- B. Related Sections include the following:
  - 1. Division 26 Section "Fuses."
  - 2. Division 26 Section "Transient Voltage Suppression."
  - 3. Division 26 Section "Electrical Special Inspections and Testing."

1.2 SUMMARY

- A. This Section includes service and distribution switchboards rated 600 V and less.

1.3 DEFINITIONS

- A. EMI: Electromagnetic interference.
- B. GFP: Ground-fault protection.
- C. TVSS: Transient voltage surge suppressor.

1.4 SUBMITTALS

- A. Product Data: For each type of switchboard, overcurrent protective device, transient voltage suppression device, ground-fault protector, accessory, and components. Include dimensions and manufacturers' technical data on features, performance, electrical characteristics, ratings, and finishes.
- B. Shop Drawings: For each switchboard and related equipment.
  - 1. Dimensioned plans, elevations, sections, and details, including required clearances and service space around equipment. Show tabulations of installed devices, equipment features, and ratings. Include the following:
    - a. Enclosure types and details for types other than NEMA 250, Type 1.
    - b. Bus configuration, current, and voltage ratings.
    - c. Short-circuit current rating of switchboards and overcurrent protective devices.
    - d. Descriptive documentation of optional barriers specified for electrical insulation and isolation.
    - e. Features, characteristics, ratings, and factory settings of individual overcurrent protective devices and auxiliary components.
    - f. Front elevation showing the arrangement of all overcurrent protective devices.



- C. Operation and Maintenance Data: For switchboards and components to include in emergency, operation, and maintenance manuals. In addition to items specified in Division 01 Section "Operation and Maintenance Data," include the following:
  - 1. Routine maintenance requirements for switchboards and all installed components.
  - 2. Manufacturer's written instructions for testing and adjusting overcurrent protective devices.
  - 3. Time-current curves, including selectable ranges for each type of overcurrent protective device.

#### 1.5 QUALITY ASSURANCE

- A. Source Limitations: Obtain switchboards through one source from a single manufacturer.
- B. Electrical Components, Devices, and Accessories: Listed and labeled as defined in NFPA 70, Article 100, by a testing agency acceptable to authorities having jurisdiction, and marked for intended use.
- C. Comply with NEMA PB 2, "Deadfront Distribution Switchboards."
- D. Comply with NFPA 70.
- E. Codes and Standards:
  - 1. Electrical Code Compliance: Comply with applicable local code requirements of the authority having jurisdiction as applicable to installation, and construction of service-entrances.
  - 2. NEMA Compliance: Comply with applicable construction and installation requirements for service-entrance equipment and accessories.
  - 3. UL Compliance: Comply with construction and installation requirements of UL standards for service-entrance equipment and accessories.
  - 4. Provide service-entrance equipment and accessories which are UL-listed and labeled, and marked, "SUITABLE FOR USE AS SERVICE EQUIPMENT (SUSE)."
  - 5. IEEE Compliance: Comply with applicable requirements of IEEE Std 241 pertaining to service entrances.
  - 6. Comply with ANSI installation requirements for aboveground service-entrance conductors.

#### 1.6 DELIVERY, STORAGE, AND HANDLING

- A. Deliver in sections or lengths that can be moved past obstructions in delivery path.
- B. Store indoors in clean dry space with uniform temperature to prevent condensation. Protect from exposure to dirt, fumes, water, corrosive substances, and physical damage.
- C. If stored in areas subjected to weather, elevate the switchboards to prevent direct contact to earth or concrete slabs and cover switchboards (minimum 20 mil plastic sheeting) to provide protection from weather, dirt, dust, corrosive substances, and physical damage. Remove loose packing and flammable materials from inside switchboards; install electric heating (250 W per section) to prevent condensation.

- D. Handle switchboards according to NEMA PB 2.1 and NECA 400.

#### 1.7 COORDINATION

- A. Coordinate layout and installation of switchboards and components with other construction including conduit, piping, equipment, and adjacent surfaces. Maintain required workspace clearances and required clearances for equipment access doors and panels.
- B. Coordinate size and location of concrete bases. Cast anchor-bolt inserts into bases. Concrete, reinforcement, and formwork requirements are specified in Division 03.

### PART 2 - PRODUCTS

#### 2.1 MANUFACTURERS

- A. Manufacturer: Subject to compliance with requirements, provide the products by one of the following:
  - 1. Cutler-Hammer.
  - 2. General Electric Co.
  - 3. Square D.
- B. Front-Connected, Front-Accessible Switchboard: All sections shall be front and rear aligned.
- C. Enclosure: Steel, NEMA 250, Type 1 or 3R where installed outdoors.
- D. Enclosure Finish for Outdoor Units: Factory-applied finish in manufacturer's standard color, undersurfaces treated with corrosion-resistant undercoating.
- E. Enclosure Finish for Indoor Units: Factory-applied finish in manufacturer's standard gray finish over a rust-inhibiting primer on treated metal surface.
- F. Provide space for non-utility metering / monitoring meter.
- G. Bus Transition and Incoming Pull Sections: Matched and aligned with basic switchboard.
- H. Hinged Front Panels: Allow access to circuit breaker, metering, accessory, and blank compartments.
- I. Buses and Connections: Three phase, four wire, unless otherwise indicated.
  - 1. Phase- and Neutral-Bus Material: Tin-plated aluminum with copper feeder circuit breaker line connections.
  - 2. Load Terminals: Insulated, rigidly braced, silver-plated, copper runback bus extensions equipped with pressure connectors for outgoing circuit conductors. Provide load terminals for future circuit-breaker positions at full ampere rating of circuit-breaker position.

I-CO  
VED  
Y COMM  
Go  
2-12

3. Ground Bus: 1/4-by-2-inch- (6-by-50-mm-) minimum-size, hard-drawn copper of 98 percent conductivity, equipped with pressure connectors for feeder and branch-circuit ground conductors. For busway feeders, extend insulated equipment grounding cable to busway ground connection and support cable at intervals in vertical run.
  4. Contact Surfaces of Buses: Silver plated.
  5. Main Phase Buses, Neutral Buses, and Equipment Ground Buses: Uniform capacity for entire length of switchboard's main and distribution sections. Provide for future extension.
  6. Isolation Barrier Access Provisions: Permit checking of bus-bolt tightness.
  7. Neutral Buses: 100 percent of the ampacity of phase buses, unless otherwise indicated, equipped with pressure connectors for outgoing circuit neutral cables. Bus extensions for busway feeder neutral bus are braced.
  8. Each section(s) shall be provided with maximum vertical height phase bussing available or more unit for breaker mounting space within one full height switchboard enclosure. The remainder of the unused bused space shall be provided with blank filler plates ready for future use.
  9. Main Phase Buses and Neutral Bus: The ampere bus ratings in its entire length shall not be reduced or tapered for both the horizontal and vertical busing in each switchboard enclosure.
- J. Future Devices: Equip compartments with mounting brackets, supports, bus connections, and appurtenances at full rating of circuit-breaker compartment.
- K. Bus-Bar Insulation: Factory-applied, flame-retardant, tape wrapping of individual bus bars or flame-retardant, spray-applied insulation. Minimum insulation temperature rating: 105 deg C.

## 2.2 SERVICE-ENTRANCE EQUIPMENT SECTION

- A. General: Provide service-entrance equipment and accessories; of types, sizes, ratings and electrical characteristics indicated, which comply with manufacturer's standard materials, design and construction in accordance with published product information, and as required for complete installation; and as herein specified.
- B. TVSS (Transient Voltage Surge Suppression): Provide TVSS system integral within the service equipment which shall be factory installed and completely connected. The component shall be part of the equipment's U.L. labeling. Refer to Division 26 Section "Transient Voltage Suppression."

## 2.3 OVERCURRENT PROTECTIVE DEVICES

- A. Molded-Case Circuit Breaker: NEMA AB 3, with interrupting capacity to meet available fault currents.
1. Thermal-Magnetic Circuit Breakers: Quick-make, quick-break toggle mechanism with inverse time-current element for low-level overloads, and instantaneous magnetic trip element for short circuits.
  2. Adjustable Instantaneous-Trip Circuit Breakers: provide for circuit-breaker frame sizes 250 A and larger magnetic trip element with front-mounted, field-adjustable trip setting.

## SWITCHBOARDS

DES  
FIELD  
UNITY DI  
911-  
BY

3. Electronic trip-unit circuit breakers, provide for circuit-breaker frame sizes 600A and larger: Shall have RMS sensing, field-replaceable rating plug, and the following field-adjustable settings:
    - a. Instantaneous trip.
    - b. Long- and short-time pickup levels.
    - c. Long- and short-time time adjustments.
    - d. Ground-fault pickup level, time delay, and  $I^2t$  response.
  4. GFCI Circuit Breakers: Single- and two-pole configurations with 5-mA trip sensitivity.
- B. Molded-Case Circuit-Breaker Features and Accessories: Standard frame sizes, trip ratings, and number of poles.
1. Lugs: Mechanical style, suitable for number, size, trip ratings, and conductor material.
  2. Application Listing: Appropriate for application provide type HACR for heating, air-conditioning and refrigerating equipment.
  3. Shunt Trip: When specified or required, provide 120-V trip coil energized from a separate circuit, set to trip at 75 percent of rated voltage.

#### 2.4 ACCESSORY COMPONENTS AND FEATURES

- A. Furnish accessory set including tools and miscellaneous items required for overcurrent protective device test, inspection, maintenance, and operation.

### PART 3 - EXECUTION

#### 3.1 EXAMINATION

- A. Examine elements and surfaces to receive switchboards for compliance with installation tolerances and other conditions affecting performance.
- B. Proceed with installation only after unsatisfactory conditions have been corrected.

#### 3.2 INSTALLATION

- A. Install switchboards and accessories according to NEMA PB 2.1 and NECA 40.
- B. Provide concrete housekeeping base and anchor the switchboards level on the concrete base. The concrete materials and installation requirements are specified in Division 03.
1. For switchboards, install epoxy-coated anchor bolts that extend through concrete base and anchor into structural concrete floor.
  2. Place and secure anchorage devices. Use setting drawings, templates, diagrams, instructions, and directions furnished with items to be embedded.
  3. Install anchor bolts to elevations required for proper attachment to switchboards.
  4. Coordinate and receive approval of Service Entrance Switchboard's concrete base with serving utility.
- C. Temporary Lifting Provisions: Remove temporary lifting eyes, channels, and brackets and temporary blocking of moving parts from switchboard units and components.

### SWITCHBOARDS

CO  
VELOPM  
all  
est

- D. Operating Instructions: Frame and mount the printed basic operating instructions for switchboards. Fabricate frame of finished wood or metal and cover instructions with clear acrylic plastic. Mount on front of switchboards.
- E. Install overcurrent protective devices, transient voltage suppression devices, and instrumentation.
  - 1. Set field-adjustable switches and circuit-breaker trip ranges.
  - 2. Settings shall be based on "Coordination Study" as defined in this Section.

3.3 IDENTIFICATION

- A. Identify field-installed conductors, interconnecting wiring, and components; provide warning signs as specified in Division 26 Section "Identification for Electrical Systems."

3.4 CLEANING

- A. On completion of installation, inspect interior and exterior of switchboards. Remove paint splatters and other spots. Vacuum dirt and debris; do not use compressed air to assist in cleaning. Repair exposed surfaces to match original finish.

3.5 DEMONSTRATION

- A. Engage a factory-authorized service representative to train Owner's maintenance personnel to adjust, operate, and maintain switchboards, overcurrent protective devices, instrumentation, and accessories. Refer to Division 01.

END OF SECTION

BY  
ENT